

# ISLA

Components Ltd

Issue 8



## WIPER ARM & WIPER BLADE GUIDE

# PANTOGRAPH ARM

Pantograph System

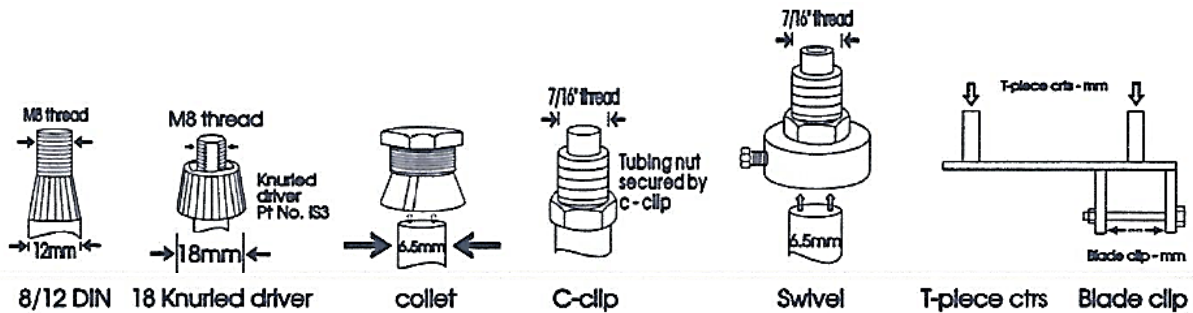
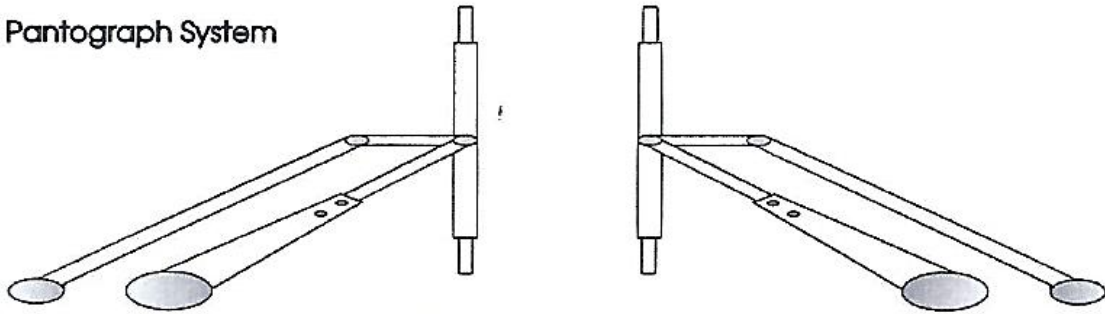

PART NO. / LENGTH (INS)	MAIN HEAD (mm)	IDLER HEAD (mm)	T-PIECE (mm)	BLADE CLIP (mm)	CRANK
CXA10 -	18 knurled driver	6.5 C-Clip	50	13.6	Straight
CXA11 -	18 knurled driver	6.5 C-Clip	65	13.6	Straight
CXA12 -	18 knurled driver	6.5 C-Clip	45	13.6	Straight
CXA13 -	18 knurled driver	6.5 Swivel	50	13.6	Straight
CXA14 -	8/12 DIN	6.5 C-Clip	50	13.6	Straight
CXA15 -	8/12 DIN	6.5 Collet	45	13.6	Straight
CXA16 -	8/12 DIN	6.5 Swivel	50	13.6	Straight
CXA20 -	8/12 DIN	6.5 C-Clip	50	13.6	Inward
CXA21 -	18 knurled driver	6.5 Swivel	57	13.6	Straight

ADD WW TO PART NUMBER IF A WASH WIPE IS REQUIRED

Order code example – CXA1428WW

# PANTOGRAPH ARM



8/12 DIN  
Main Head



8/12 DIN  
Idler Head

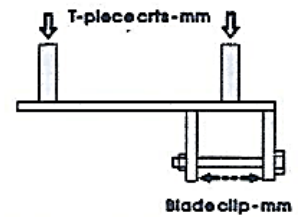

T-piece crts    Blade clip

PART NO. / LENGTH (INS)	MAIN HEAD (mm)	IDLER HEAD (mm)	T-PIECE (mm)	BLADE CLIP (mm)	CRANK
CXA17 -	8/12 DIN	8/12 DIN	60	17	Straight
CXA18 -	8/12 DIN	8/12 DIN	60	17	Inward
CXA19 -	8/12 DIN	8/12 DIN	50	13.6	Straight
CXA22 -	8/12 DIN	8/12 DIN	50	13.6	Inward
CXA23 -	8/12 DIN	8/12 DIN	60	28/23	Straight
CXA24 -	8/12 DIN	8/12 DIN	60	28/23	Inward
CXA38 -	8/12 DIN	8/12 DIN	50	28/23	Straight
CXA39 -	8/12 DIN	8/12 DIN	50	28/23	Inward
CXA40 -	8/12 DIN	8/12 DIN	50	17	Straight
CXA41 -	8/12 DIN	8/12 DIN	50	17	Inward

ADD WW TO PART NUMBER IF A WASH WIPE IS REQUIRED

Order code example – CXA2430WW

# PANTOGRAPH ARM



8/12 DIN  
Main Head



8/12 DIN  
Idler Head

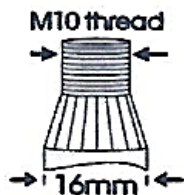

10/16 DIN  
Main Head

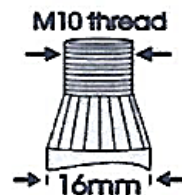

10/16 DIN  
Idler Head

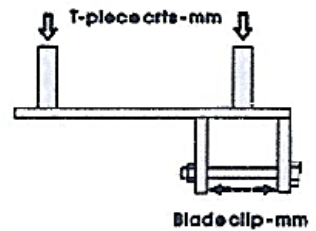

T-piece crts    Blade clip

PART NO. / LENGTH (INS)	MAIN HEAD (mm)	IDLER HEAD (mm)	T-PIECE (mm)	BLADE CLIP (mm)	CRANK
CXA42 -	10/16 DIN	Collet	60	13.6	Straight
CXA43 -	10/16 DIN	8/12 DIN	60	13.6	Inward
CXA44 -	10/16 DIN	6.5 C-Clip	50	17	Straight
CXA80 -	10/16 DIN	8/12 DIN	60	13.6	Inward
CXA81 -	10/16 DIN	8/12 DIN	60	17	Straight
CXA828 -	8/12 DIN	Parallel	60	28/23	Straight
CXA928 -	Parallel	Parallel	60	28/23	Straight

ADD WW TO PART NUMBER IF A WASH WIPE IS REQUIRED

Order code example – CXA4330WW



# LIGHTWEIGHT JUMBO PANTOGRAPH ARM (12mm Box Section)



8/12 DIN

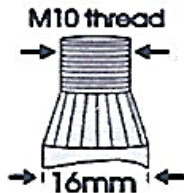

10/16 DIN

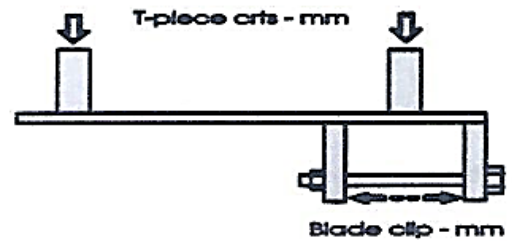

T-piece crts

Blade clip

PART NO. / LENGTH (INS)	MAIN HEAD (mm)	IDLER HEAD (mm)	T-PIECE (mm)	BLADE CLIP (mm)	CRANK
CXA60 -	10/16 DIN	8/12 DIN	60	28/23	Inward
CXA61 -	10/16 DIN	8/12 DIN	60	28/23	Straight
CXA62 -	10/16 DIN	10/16 DIN	60	28/23	Inward
CXA62 -	10/16 DIN	10/16 DIN	60	28/23	Straight
CXA64 -	10/16 DIN	8/12 DIN	45	13.6	Straight
CXA65 -	10/16 DIN	8/12 DIN	60	13.6	Straight
CXA66 -	10/16 DIN	8/12 DIN	60	17	Inward
CXA67 -	10/16 DIN	8/12 DIN	60	17	Straight
CXA68 -	10/16 DIN	10/16 DIN	60	17	Inward
CXA69 -	10/16 DIN	10/16 DIN	60	17	Straight

WW IS ADDED TO ALL JUMBO PANTOGRAPHS AS STANDARD

Order code example – CXA6231WW

# STANDARD JUMBO PANTOGRAPH ARM (16mm Box Section)



8/12 DIN

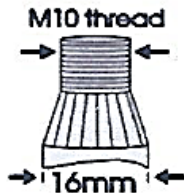

10/16 DIN

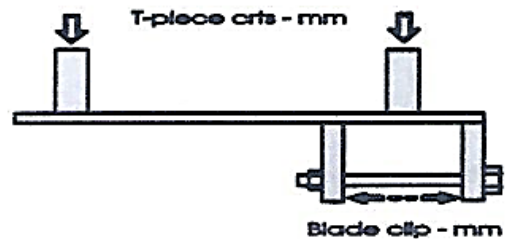

T-piece crts

Blade clip

PART NO. / LENGTH (INS)	MAIN HEAD (mm)	IDLER HEAD (mm)	T-PIECE (mm)	BLADE CLIP (mm)	CRANK
CXA70 -	10/16 DIN	8/12 DIN	60	28/23	Inward
CXA71 -	10/16 DIN	8/12 DIN	60	28/23	Straight
CXA71 -	10/16 DIN	10/16 DIN	60	28/23	Inward
CXA73 -	10/16 DIN	10/16 DIN	60	28/23	Straight
CXA74 -	10/16 DIN	8/12 DIN	45	13.6	Straight
CXA75 -	10/16 DIN	8/12 DIN	60	13.6	Straight
CXA76 -	10/16 DIN	8/12 DIN	60	17	Inward
CXA77 -	10/16 DIN	8/12 DIN	60	17	Straight
CXA78 -	10/16 DIN	10/16 DIN	60	17	Inward
CXA79 -	10/16 DIN	10/16 DIN	60	17	Straight

WW IS ADDED TO ALL JUMBO PANTOGRAPHS AS STANDARD

Order code example – CXA7231WW

# SINGLE ARM



8/12 DIN  
Main Head

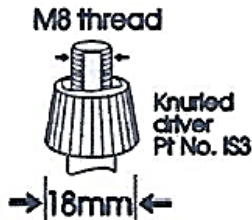

18 Knurled driver

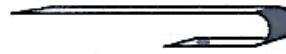

9mm Hook

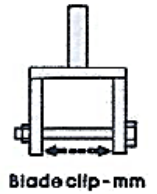

Blade clip

PART NO. / LENGTH (INS)	MAIN HEAD (mm)	BLADE CLIP (mm)	CRANK DEGREES	LENGTH RANGE(INS)	
AWX50 -	18 knurled driver	13.6	Adjustable	15-32	<div style="display: flex; justify-content: space-around;"> <span>R/H</span> <span>L/H</span> </div> <p>Viewed from outside vehicle</p>
AWX51 -	8/12 DIN	13.6	Adjustable	15-32	
AWX52 -	8/12 DIN	17	Adjustable	15-32	
AWX53 -	18 knurled driver	13.6	Straight	15-32	
AWX54 -	8/12 DIN	13.6	Straight	15-32	
AWX55 -	8/12 DIN	17	Straight	15-32	
AWX56 -	18 knurled driver	13.6	7' Left	15-32	
AWX57 -	18 knurled driver	13.6	12' Left	15-32	
AWX58 -	18 knurled driver	13.6	7' Left	15-32	
AWX59 -	18 knurled driver	13.6	12' Left	15-32	
AWX60 -	8/12 DIN	13.6	7' Left	15-32	
AWX61 -	8/12 DIN	13.6	12' Left	15-32	
AWX62 -	8/12 DIN	13.6	7' Left	15-32	
AWX63 -	8/12 DIN	13.6	12' Left	15-32	
AWX64 -	8/12 DIN	9 hook	12' Left	15-24	
AWX65 -	8/12 DIN	9 hook	12' Right	15-24	
AWX66 -	8/12 DIN	9 hook	Straight	15-24	

ADD WW TO PART NUMBER IF A WASH WIPE IS REQUIRED

Order code example – AWX6220WW

# RADIAL ARMS

## Radial System - viewed from outside vehicle

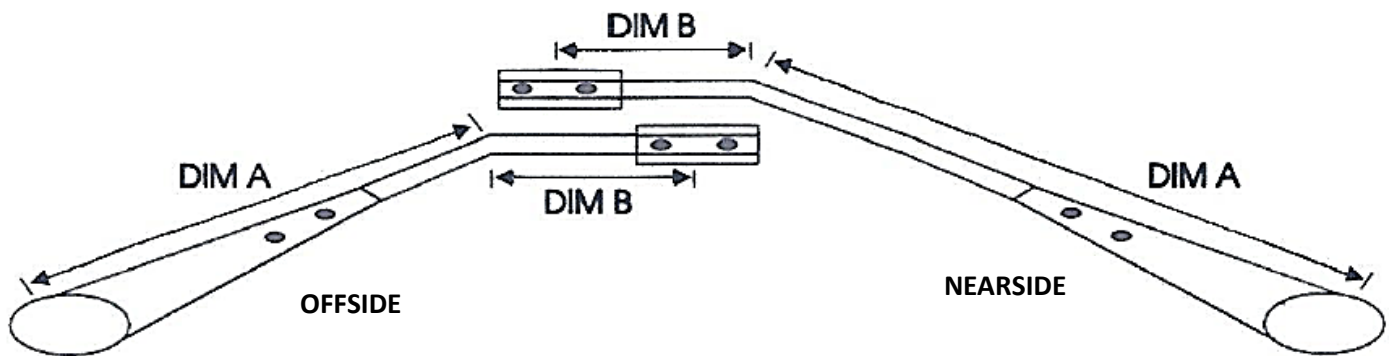

### Identifying Radial Arms:

1. Nearside or Offside being measured?
2. Measure Dimension A ( Centre of spindle to bend) and Dimension B (Bend to middle of blade clip)
3. What side head is required? E.g 10/16 , 12/16
4. Do you need a wash wipe on the arm?



# BLANK MEASUREMENT TEMPLATE

Please use the below template to provide measurements taken from your existing arm.  
Once complete please email to [callum@islacomponents.co.uk](mailto:callum@islacomponents.co.uk)

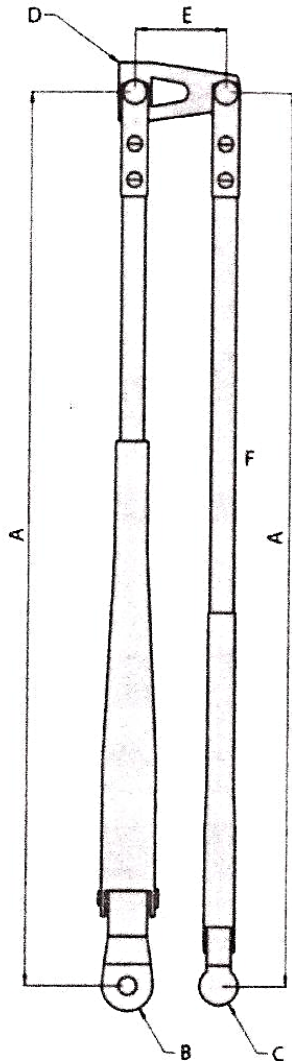

**A = LENGTH**

**B = MAIN HEAD TAPER**

**C = IDLER FIXING**



I.E 6mm STD or 8/12 TAPER



**D = CLIP TYPE**

I.E. 13.6mm 17mm

**E = BRIDGE CR,S**

**F = BUILD TYPE**

**CHANNEL OR BOX SECTION**

**PLEASE GIVE ALL DIMENSIONS IN MM**

**QUANTITY REQUIRED:**

**CUSTOMER DETAILS:**

**COMPANY NAME –**

**CONTACT NAME –**

**PHONE NUMBER –**

**EMAIL (for quoting) -**





**PERFORMANCE  
AND VISIBILITY**

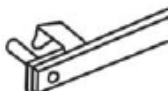

# OE REPLACEMENT FLAT WIPER BLADES ADAPTER REFERENCES

Adapter Type **A**  Arm Type Side Lock Pin 



There is a side location pin on the wiper arm, which locates in the blade adapter. Currently the most popular adapter filament type.

Adapter Type **F**  Arm Type Top Lock Side Pin 



This is a top loading pin assembly into the adapter on the blade, which looks very similar to the E adapter. Some suppliers provide an insert.

Adapter Type **B**  Arm Type Rear Pinch Lock 



The arm for this adapter has a rear assembly location, which is assembled to the arm pinching together the ends of the adapter.

Adapter Type **G**  Arm Type Arm Top Lock 



The wiper arm location and adapter have a long location and care should be noted when removing the old wiper blade.

Adapter Type **C**  Arm Type Top Push Button 



This arm has a square locating top hole, which locates on the square locating peg on the adapter.

Adapter Type **G+**  Arm Type Arm Top Lock 



Filament is the same as the G adapter with the only difference being the longer end caps at the top end in the parked vehicle position.

Adapter Type **C2**  Arm Type Top Push Button Narrow Fit 



Again this adapter and its assembly operation is exactly as adapter C, the difference being that this adapter is slightly narrower.

Adapter Type **H**  Arm Type Side Pin Lock Wide Fit with Cover 



The assembly of the arm to the blade is as our A and A2 adapters, with the only difference being that the actual filament is slightly wider, and is hidden by the cover.

Adapter Type **D**  Arm Type Bayonet Top Lock 



The arm, which assembles to this adapter has a bayonet location and fits directly into the top of the adapter.

Adapter Type **KA**  Arm Type Side Lock Pin Offset Fit 

There is a side location pin on the wiper arm, which locates in the blade adapter, which is offset.

Adapter Type **E**  Arm Type Top Lock Pin 

Original filament has a long cover, which is not required to fit the Sibak blade as an improved much smaller locking cap is used.

Adapter Type **U**  Arm Type 9x3 Hook 9x4 Hook 

Retro/Upgrade Universal Flat Blade. supplied complete with pre-filled 9x4mm 9x3mm adapter and is an option to the metal wiper blade.





# UNIVERSAL MULTI-FIT AERO BLADES

Flat wiper blades feature a totally new style and technology and are fast becoming the standard fit on new vehicles. These types of wiper blades do not have a metal 'coat hanger' shaped frame. Instead they have a tensioned metal strip running within the rubber structure of the wiper blade. This design allows for a flatter aerodynamic shape which reduces wind noise. The internal metal strip applies constant pressure along the length of the blade and has a built in spoiler. Being smaller than a conventional wiper it also provides less obstruction to the driver's field of vision.

MULTI DIRECT FIT WIPER BLADES	
BLADE SIZE	ADAPTER IN THE BOX
MDF145	C
MDF155	A,B,C,C2,D
MDF165	A,B,C,C2,D
MDF175	A
MDF185	A,B,C,C2,D
MDF195	A,B,C,C2,D
MDF205	A,B,C,C2
MDF215	A,B,C,C2,D
MDF225	A,B,C,C2,D
MDF235	A,B,C,D
MDF245	A,B,C,C2,D
MDF265	A,B,C,C2,D
MDF285	A,B,C,C2
MDF305	A,B,C,C2
MDF325	A,B,C,C2

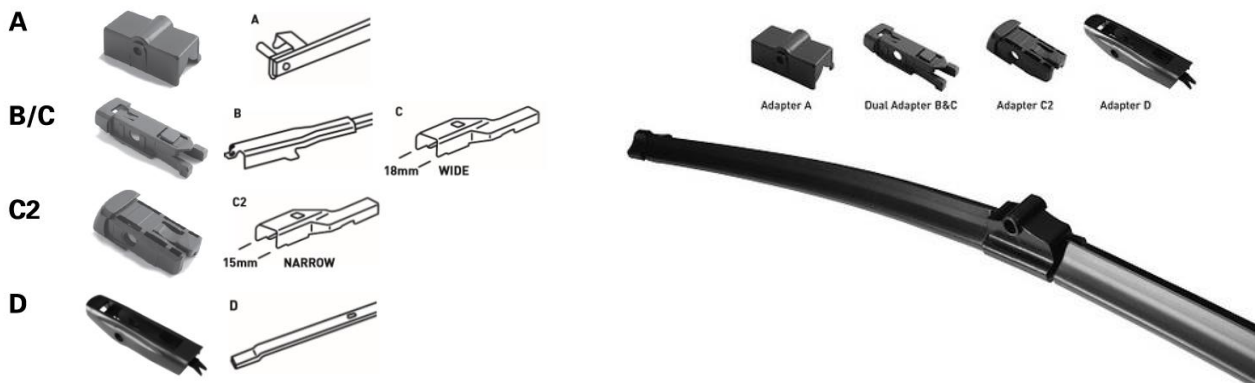

# CONVENTIONAL CAR WIPER BLADE



Standard wiper blades are the most common type of windscreen wiper, often referred to as looking like a coat hanger and are still fitted to the majority of new vehicles, although this is in decline. They are usually attached to the vehicle using a hook shape wiper arm fitting. Sizes range from 10" to 28" and it is not uncommon to have different sizes fitted to the drivers and passengers sides of the windscreen. If you already have these fitted they can easily be replaced with either another set of standard wipers or the new type of flat wiper blade upgrade.

PART NUMBER	LENGTH	DESCRIPTION
CB10	10" / 250mm	9 x 4/9x3mm hook fitting adapter
CB11	11" / 280mm	9 x 4/9x3mm hook fitting adapter
CB12	12" / 305mm	9 x 4/9x3mm hook fitting adapter
CB13	13" / 330mm	9 x 4/9x3mm hook fitting adapter
CB14	14" / 355mm	9 x 4/9x3mm hook fitting adapter
CB15	15" / 380mm	9 x 4/9x3mm hook fitting adapter
CB16	16" / 405mm	9 x 4/9x3mm hook fitting adapter
CB17	17" / 430mm	9 x 4/9x3mm hook fitting adapter
CB18	18" / 455mm	9 x 4/9x3mm hook fitting adapter
CB19	19" / 480mm	9 x 4/9x3mm hook fitting adapter
CB20	20" / 500mm	9 x 4/9x3mm hook fitting adapter
CB21	21" / 530mm	9 x 4/9x3mm hook fitting adapter
CB22	22" / 550mm	9 x 4/9x3mm hook fitting adapter
CB24	24" / 600mm	9 x 4/9x3mm hook fitting adapter
CB26	26" / 650mm	9 x 4/9x3mm hook fitting adapter
CB28	28" / 700mm	9 x 4/12x4mm hook fitting adapter













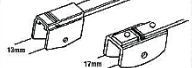



# COMMERCIAL AND LCV WIPER BLADES

Part Reference	Wiper Arm Adapters
CV209	9x4/9x3mm hook
CV20X	13/17mm bridge Nut & Bolt
CV22X	13/17mm bridge Nut & Bolt
CV229	9x4/9x3mm hook
CV22/912	12x4/9x4mm hook + s/hook
CV22W	9x4/9x3mm hook + wash wipe
CV24X	13/17mm bridge Nut & Bolt
CV24/912	12x4/9x4mm hook + s/hook
CV24W	9x4/9x3mm hook + wash wipe
CV26X	13/17mm bridge Nut & Bolt
CV26/912	12x4/9x4mm hook + s/hook
CV26W	9x4/9x3mm hook + wash wipe
CV26/14	14x4mm hook + s/hook
CV26X	13/17mm bridge Nut & Bolt
CV28/912	12x4/9x4mm hook + s/hook
CV28W	12x4/9x4mm hook + s/hook
CV28X	13/17mm bridge Nut & Bolt
CV30X	13/17mm bridge Nut & Bolt
CV309	9x4/9x3mm hook
CV32X	13/17mm bridge Nut & Bolt
CV32LX	22/25/27mm bridge Nut & Bolt
CV36LX	22/25/27mm bridge Nut & Bolt
CV36RH	16x6mm reverse hook
CV40LX	22/25/27mm bridge Nut & Bolt
CV40RH	16x6mm reverse hook

## EXPLANATION OF PART NUMBER REFERENCES

CV	Commercial Vehicle
20-40	Blade Length in Inches
X	13 / 17mm Bridge/Saddle Fitting
9	9x4 / 9x3mm Hook Fitting
912	9x4 / 12x4mm Hook Fitting
14	14x4mm hook + s/hook
W	Wash Wipe Spray Jet Fitted
LX	22 / 25 / 27mm Bridge/Saddle Fitting
RH	Reverse Hook Fitting
SH	9x4mm Short Hook Fitting

 <b>MULTIFIT Adapter</b>	 9 x 3mm 9 x 4mm <b>9x3mm &amp; 9x4mm Hook Arm</b>	 <b>17mm Spacer</b>	 <b>13mm &amp; 17mm Saddle</b>
 <b>MULTIFIT Adapter</b>	 9mm 4mm <b>9x3mm &amp; 9x4mm + SPRAY NOZZLE</b>	 <b>22mm, 25mm &amp; 27mm Spacer</b>	 22mm 25mm 27mm <b>22mm, 25mm &amp; 27mm Saddle</b>
 <b>12x4mm Hook Adapter</b>	 12mm 4mm <b>9 x 4 &amp; 12x4mm Hook Arm</b>	 <b>Twin Screw Bayonet</b>	 8mm 2mm <b>8mm x 2mm &amp; 8mm x 3mm</b>
 <b>9x4mm Short Hook Adapter</b>	 9mm 4mm <b>9x4mm Hook Arm</b>	 <b>16x6mm Hook Adapter</b>	 16mm 6mm <b>16x6mm Hook Arm</b>

# PLANT & AGRICULTURAL BLADES & ARMS



PART NUMBER	LENGTH	FITS OTHER PRODUCT
IS.07.0250	250mm	IS.08, IS.10, IS.11
IS.07.0300	300mm	IS.08, IS.10, IS.11
IS.07.0350	350mm	IS.08, IS.10, IS.11
IS.07.0400	400mm	IS.08, IS.10, IS.11
IS.07.0450	450mm	IS.08, IS.10, IS.11
IS.07.0500	500mm	IS.08, IS.10, IS.11



PART NUMBER	LENGTH	SPINDLE FIXATION	FITS OTHER PRODUCT
IS.08.3040	300-400mm	6mm	IS.07
IS.08.4050	400-500mm	6mm	IS.07
IS.10.3040	300-400mm	A8 x M6	IS.07
IS.10.4050	400-500mm	A8 x M6	IS.07
IS.11.3040	300-400mm	A8 x M6	IS.07
IS.11.4050	400-500mm	A8 x M6	IS.07



PART NUMBER	LENGTH	SPINDLE FIXATION	FITS OTHER PRODUCT
IS.12.3040	300-400mm	A8 x M6	IS.07
IS.12.4050	400-500mm	A8 x M6	IS.07
IS.12.5060	500-600mm	A8 x M6	IS.07
IS.12.4052	400-500mm	A10 x M8	IS.07
IS.12.5062	500-600mm	A10 x M8	IS.07

# WASHER BOTTLES

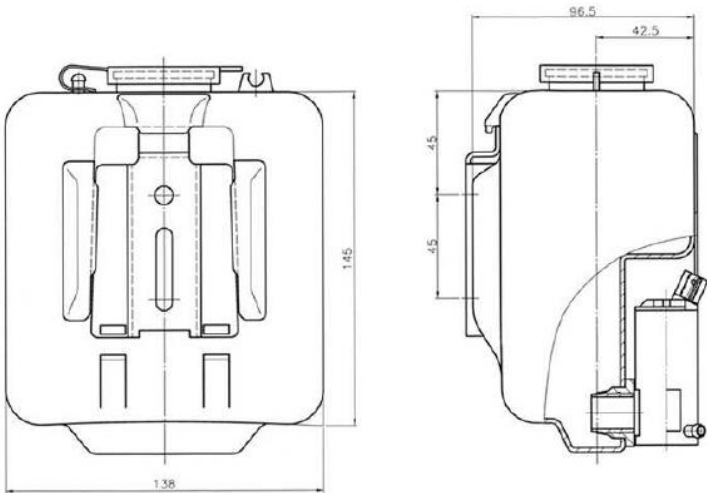

PART NUMBER	VOLUME	PUMPS	VOLT
IS.02.0412	1.25L	1	12V
IS.02.0424	1.25L	1	24V

# AGRICULTURE & PLANT OE CROSS REFERENCE

Did you know we also stock a wide range of Agricultural & Plant Vehicle Wiper Components?  
Click here to check out our OE Cross Referencing List



Isla Components Ltd – Unit 5 Court Farm Technology Park – Bishops Frome – Worcester – WR6 5AY –



**MORE THAN JUST A WIPER BLADE SUPPLIER,  
WE ALSO STOCK...**

## PLANT ARMS & BLADES



## WIPER MOTORS



## WASHER JETS, VALVES & WASHER HOSE TUBING



## ACE HOSE CLIPS



**CAN'T SEE WHAT YOU'RE LOOKING FOR?  
GIVE US A CALL, WE ARE ALWAYS HAPPY TO HELP.**